

## Temperature Ratings and Thermal Considerations For Nuvistor Tubes

This Note describes the basic rules and procedures used to establish temperature ratings for nuvistor tube types. To achieve maximum usefulness and reliability from nuvistor tubes within their published ratings, equipment designers should give careful consideration to the thermal requirements of the tubes in the early stages of design. It should be clearly understood that the maximum shell-temperature rating of a nuvistor tube is not comparable to the maximum bulb-temperature rating of a glass tube. The heat-transfer mechanisms of the nuvistor structure differ substantially from those of a glass tube; the nuvistor tube is cooled primarily by conduction rather than by radiation and convection. There is no convenient method of directly comparing the nuvistor and glass-tube temperature ratings without exhaustive measurements in a given environment. Although the bulb temperature of glass tubes is greatly affected by ambient air temperature, the surrounding glass air has little effect on the shell temperature of a nuvistor when proper contact between the shell and the chassis is provided by the tube socket. This statement applies for all normal environments, and also for many abnormal environments involving high packaging density and limited air flow.

### Need for Temperature Ratings

Temperature ratings are specified for electron tubes to minimize detrimental effects which may reach excessive magnitude if critical temperatures are exceeded. In particular, two physical processes are accelerated as the temperature of tube electrodes and the surrounding envelope increases: (1) the release of adsorbed or absorbed gases from the tube envelope and structure, and (2) the emission of electrons from all electrodes, and especially from the control grid. Of these two phenomena, gas evolution is more detrimental to tube life because it tends to destroy the emission capabilities of the cathode.

Because the control grid is normally the most negative electrode in an electron tube, it acts as a collector for positive ions produced when gases are released from other electrodes under high temperature. As a result, a variable component of negative grid current may be introduced in the external circuit.

In addition, the control grid is physically near the cathode and normally operates at a relatively high temperature because of radiated heat from the cathode. Any increase in grid temperature enhances the emitting characteristics of the grid and raises the level of primary emission from this electrode. This primary emission then adds another component of negative grid current to the ion current previously mentioned.



The construction and processing techniques used for nuvistor tubes involve extremely high temperatures and high vacuum. As a result, the amount of gas liberated from tube electrodes during normal use is negligible, and thus the value of ion current is negligible. The development of primary emission from the nuvistor control grid is, therefore, the determining factor in establishing the metal-shell temperature rating.

Because the external control-grid circuit for a vacuum tube usually has a high value of resistance, a small change in grid current due to either gas ions or grid emission can lead to a substantial change in the operating point. Both gas and grid-emission currents decrease bias; as a result, dissipation and temperature increase, and a runaway condition may develop. (For example, a 0.1-microampere increase in grid current through a 1-megohm resistor reduces the bias by 0.1 volt. In a tube having high transconductance, a 0.1-volt decrease in bias can cause a 10-per-cent increase in plate current and dissipation.) Similarly, the input impedance will be reduced substantially because of additional grid currents. The effects of grid current, although undesirable, can be greatly minimized in circuit design.

### **Physical Basis of Temperature Ratings**

For a given input power, the maximum bulb temperature of a glass tube is determined primarily by the temperature of the surrounding air because cooling is achieved largely by radiation. Nuvistor tubes are cooled primarily by heat conduction through the socket to the chassis. Therefore, chassis temperature rather than air temperature determines the maximum nuvistor metal-shell temperature for a given input power.

The temperature of the control grid in an electron tube is affected by three main factors: (1) radiation from the cathode to the grid, (2) radiation and conduction from the plate to other elements and thus externally through the glass bulb or metal shell, (3) radiation and conduction from external sources to the shell or bulb and thus to internal parts of the tube. Factors (2) and (3) are of primary concern to the circuit designer because they interact to establish the shell or bulb temperature. Furthermore, the circuit designer can control these factors to an appreciable degree.

The ceramic base wafer used in nuvistor tubes has very good thermal conductivity as compared to that of glass. This wafer, in conjunction with the metal shell, provides the easiest path for heat transfer by conduction. Radiation from the shell is extremely small. The temperature rise of the nuvistor control grid is determined by the heat radiated to the grid from the cathode and the thermal conductivity of the control-grid structure and base wafer. To establish the maximum grid temperature for stable operation, the nuvistor is rated at the base region of the shell. The term "base temperature" is often used to specify the maximum metal-shell temperature measured in the base region.

### **Temperature Measurements**

The temperature of a nuvistor shell is normally measured at the base of the tube, as shown in Fig. 1. A small thermocouple can be welded into a gusset at the base by discharging a capacitor through the junction of the thermocouple and the metal shell. A 200-microfarad capacitor charged to about 75 volts is suitable for this purpose. An alternate method is to apply commercially available temperature-sensitive paints to the base region, indicated as "Zone A" in Fig. 1.

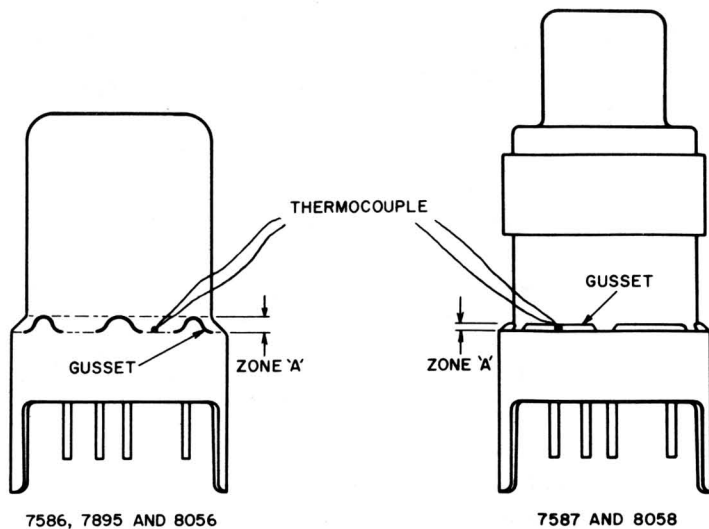

Fig. 1 - Sketch illustrating methods of measuring metal-shell temperature of nuvistors.

### Socket-Design Considerations

In the conventional nuvistor socket, heat is transferred from the nuvistor to the chassis by thermal conduction to the socket through metal contacts to the indexing lugs. Conventional sockets are available from Cinch Manufacturing Co. (socket number 133-65-10-001) and Industrial Electronic Hardware (socket numbers NU-5044 and 5060). Although these sockets provide adequate cooling in most applications, much better thermal conduction is achieved through the use of the Cinch socket number 133-65-10-041. In this socket, metal "fingers" bear against the nuvistor shell and facilitate conduction of heat to the metallic saddle. A uhf socket, Cinch number 133-67-90-040, is available for operation at frequencies in the 1000-megacycle range. This socket has a temperature rise above chassis of 33 degrees centigrade at a total power input of 1.85 watts.

### Plate-Dissipation Ratings and Chassis Temperature

Whenever possible, nuvistors should be located in the coolest region of the chassis. The temperature of the shell should be measured as described above to assure operation within ratings. Nuvistors are normally life-tested at a shell temperature of 150 degrees centigrade with maximum rated grid-circuit resistance. Fig. 2(a) shows combinations of plate dissipation and chassis temperature which produce base temperatures of 150 degrees centigrade for nuvistors tubes operating in conventional sockets under high-line conditions (heater voltage of 6.9 volts). The curves show that type 7587 may be operated at full dissipation and rated grid-circuit resistance at chassis temperatures up to 70 degrees centigrade, types 7586 and 7895 up to 85 degrees centigrade, type 8056 up to 100 degrees centigrade, and type 8058 up to 110 degrees centigrade without exceeding the maximum metal-shell temperature ratings. At high temperatures, the plate dissipation must be reduced by the indicated percentages to avoid excessive shell temperatures. The chassis temperature limitation at zero plate dissipation is lower than the shell-temperature rating because of a rise in shell temperature due to the heater power.

Fig.2(b) shows similar bulb-temperature curves for glass tubes as a function of ambient air temperatures; these curves were derived from WADC Technical Report 56-53, page 45. The curves are based on the published

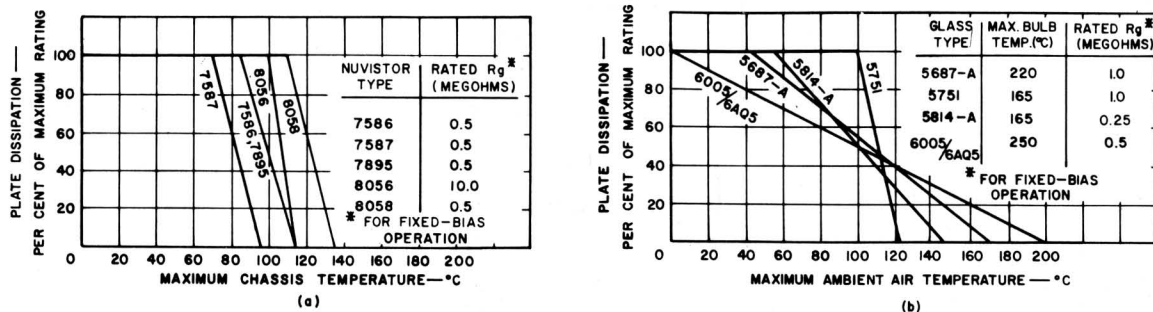

Fig.2 - Curves showing (a) metal-shell temperature of nuvistors as a function of plate dissipation and chassis temperature, and (b) bulb temperature of glass tubes as a function of plate dissipation and ambient air temperature.

maximum bulb temperature for each tube type. When the bulb-temperature rating is exceeded, poor life performance due to cathode poisoning may result. The grid-circuit-resistance value for a particular tube type is rated independently. If the grid-circuit-resistance rating is exceeded, circuit instability may occur independent of the bulb temperature.

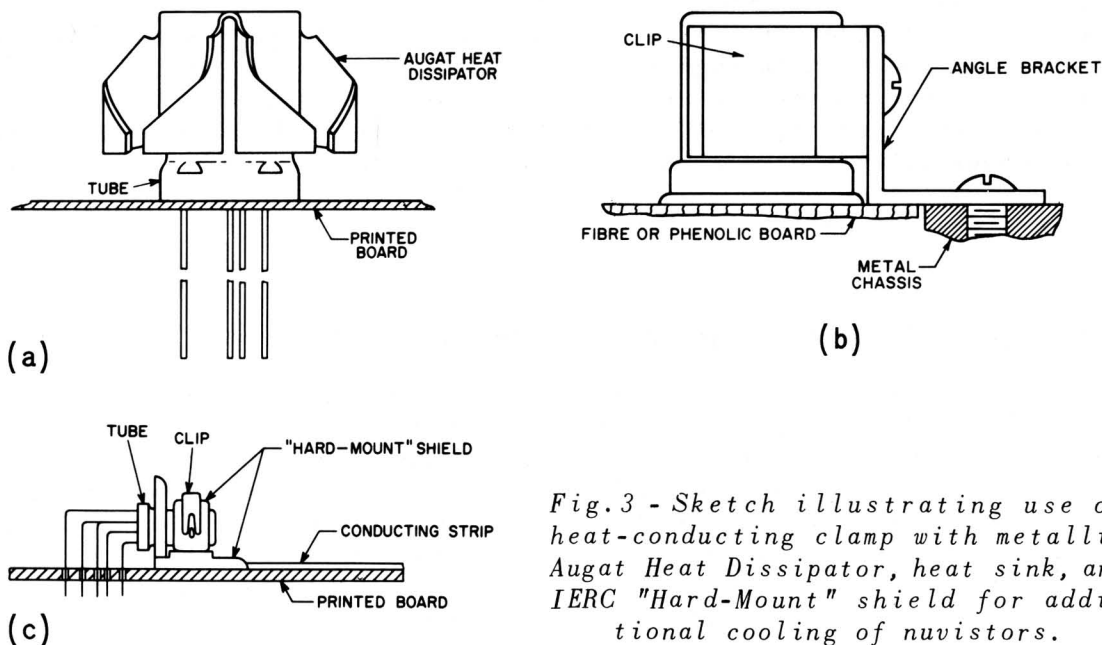

Fig.3 - Sketch illustrating use of heat-conducting clamp with metallic Augat Heat Dissipator, heat sink, and IERC "Hard-Mount" shield for additional cooling of nuvistors.

### Chassis Considerations

The curves shown in Fig.2(a) apply only to chassis made of materials having good thermal conductivity, such as steel or aluminum. When nuvistors (especially developmental long-lead types) are mounted on a low-conductivity material, such as a phenolic or fiber "printed-board" chassis,

less conduction cooling can occur, and heat is also carried away by radiation and convection. On such chassis, therefore, base temperatures are about 50 degrees centigrade higher than those shown in Fig. 2(a) unless additional cooling means are used. Fig. 3 shows three suitable cooling techniques for nuvistors: (a) the use of a 9036-1PIU heat dissipator manufactured by Augat, Inc.; (b) the use of conventional heat-conducting clips manufactured by Tinnerman Corp.; (c) the use of an International Electronics Corporation (IERC) "Hard-Mount" shield.

Figs. 4, 5, and 6 can be used as a guide in estimating base temperature for various socket, lead size, and chassis combinations for the indicated nuvistor types. Actual base-temperature measurements should be made to insure operation within ratings in printed-circuit applications and in other applications where high packaging density or wide environmental temperature ranges may create hot spots within the equipment.

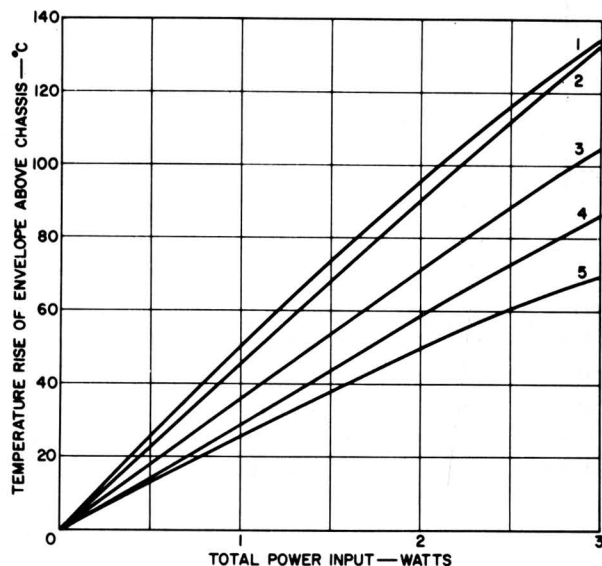
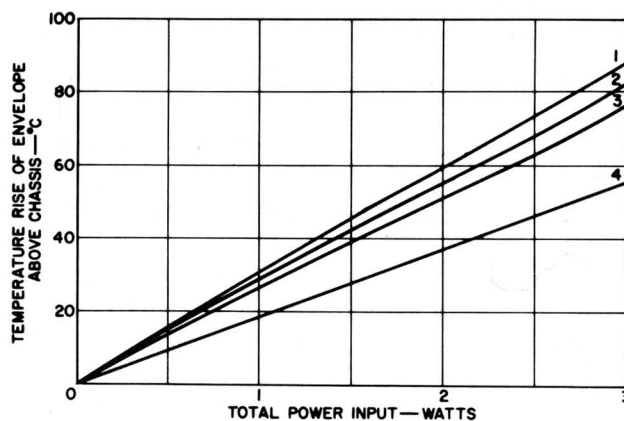

Fig. 4 - Temperature curves for (1) subminiature T-3 tubes; (2) 7586, Cinch socket 133-65-10-009 mounted on printed board; (3) 7586, conventional socket crimp-mounted on aluminum chassis; (4) 7586, Cinch socket 133-65-10-041 crimp-mounted on aluminum chassis; (5) tetrode 7587, conventional socket crimp-mounted on aluminum chassis.

Fig. 5 - Temperature curves for nuvistors triodes solder-mounted on brass chassis: (1) conventional socket, #36 wire; (2) conventional socket, #24 wire; (3) conventional socket, #16 wire; (4) Cinch socket 133-65-10-041, #24 wire.



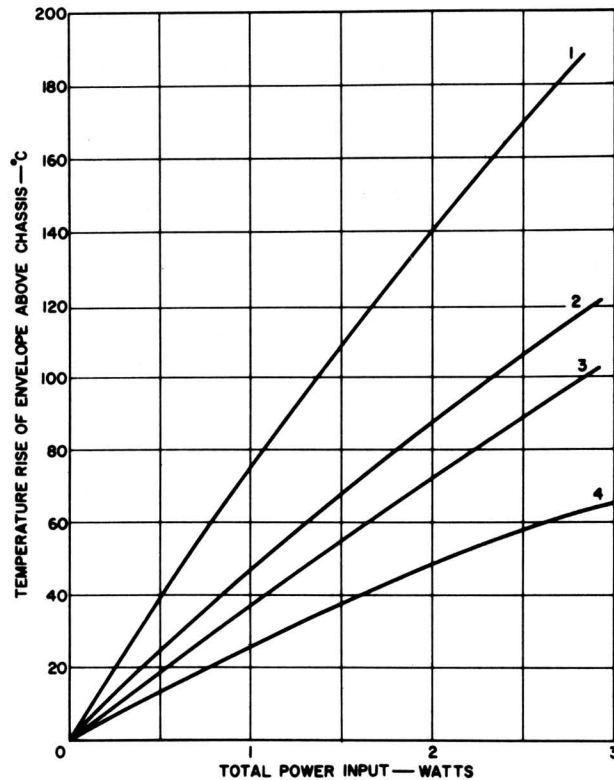

Fig.6 - Temperature curves for developmental long-lead nuvistor triodes: (1) in free air, no socket, not mounted; (2) in free air, no socket, August Heat Dissipator; (3) mounted in IERC clamp, attached to printed board, no socket; (4) mounted in IERC clamp, attached to heat sink, no socket.

### Grid-Circuit-Resistance Ratings

At a maximum shell temperature of 150 degrees centigrade, published data for the 7586, 7587, 7895, and 8058 specify a maximum value of one megohm for the control-grid-circuit resistance for cathode-bias operation. In the case of type 8056, a 10-megohm resistance is specified. The 150-degree-centigrade value approximates the typical maximum temperature rating of 85 degrees centigrade established for most conventional circuit components.

In many industrial and military applications, chassis configuration and packaging density require operation at chassis temperatures higher than 85 degrees centigrade. Conversely, in other applications temperature is not a factor, but a larger grid-circuit resistance may be required. Data have been obtained, therefore, to determine the maximum allowable control-grid-circuit resistance for individual nuvistor types at shell temperatures up to 250 degrees centigrade. These data have been measured in conventional sockets crimp-mounted on a 1/16-inch aluminum chassis.

The nomographs in Figs.7 through 11 show the relationship of grid-circuit resistance to chassis temperature and plate dissipation. Any one of these parameters can be determined from the nomographs if the other two are known. For example, if the chassis temperature and plate dissipation are known, the maximum allowable grid-circuit resistance is determined as follows:

First, the intersection of the chassis-temperature and plate-dissipation lines is located on the lower part of the nomograph. A line is then drawn vertically from this point to intersect the cathode-bias or fixed-bias line. From this intersection, a line is drawn horizontally to the left to indicate the maximum allowable grid-circuit resistance on the left-hand scale.



Conversely, if the grid-circuit resistance is known, a horizontal line is drawn from this value to intersect the cathode-bias or fixed-bias line. A vertical line is then drawn from this intersection to the lower part of the nomograph. The intersections of this vertical line with the plate-dissipation lines determine the maximum allowable chassis temperatures for given plate dissipations, or the maximum allowable plate dissipations for given chassis temperatures.

As shown in Figs. 7, 10, and 11, the maximum grid-circuit resistance for types 7586, 8056, and 8058 is 10 megohms. For types 7587 and 7895, it is 3 megohms, as shown in Figs. 8 and 9. Although larger values of

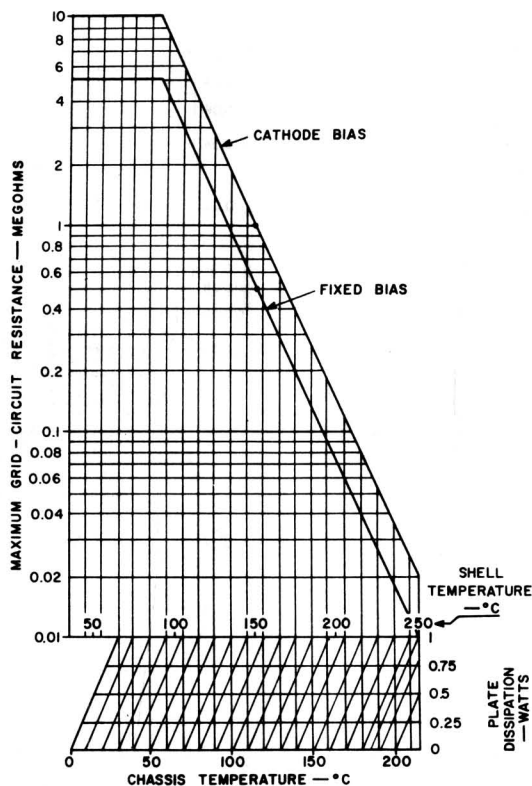

Fig. 7 - Nomograph for type 7586.

circuit resistance can sometimes be used, particularly in cathode-follower designs, circuit designers should consult the tube manufacturer for advice concerning such applications.

The maximum metal-shell temperature rating of 250 degrees centigrade for nuvistors allows operation at chassis temperatures up to 170 degrees centigrade for the 7587, 185 degrees centigrade for the 7586 and 7895, 200 degrees centigrade for the 8056, and 210 degrees centigrade for the 8058. A separate scale of actual nuvistor metal-shell temperatures is also included in the nomographs.

Information furnished by RCA is believed to be accurate and reliable. However, no responsibility is assumed by RCA for its use; nor for any infringements of patents or other rights of third parties which may result from its use. No license is granted by implication or otherwise under any patent or patent rights of RCA.

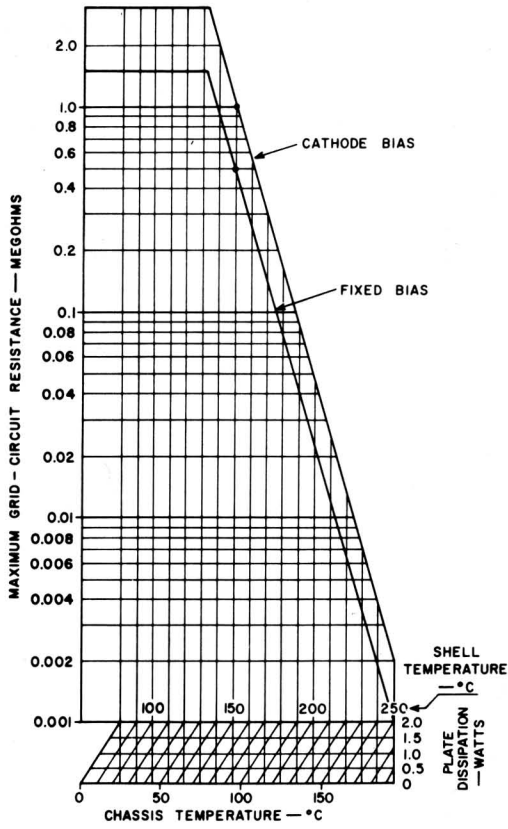

Fig. 8 - Nomograph for type 7587.

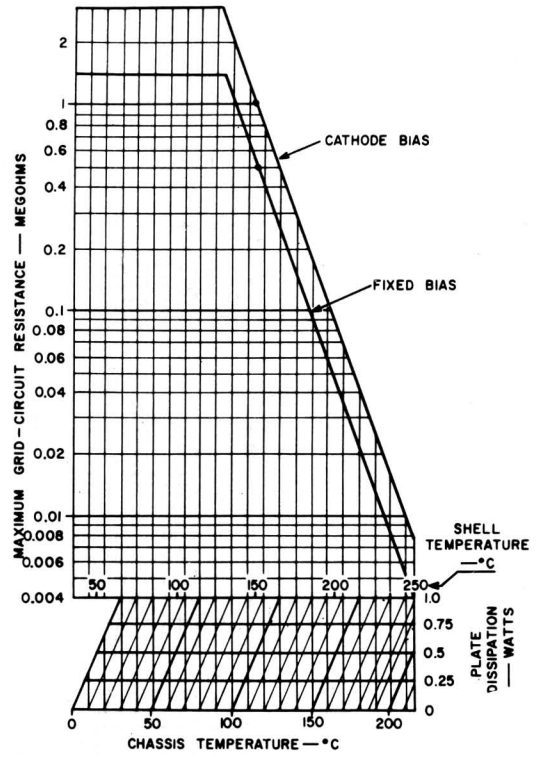

Fig. 9 - Nomograph for type 7895.

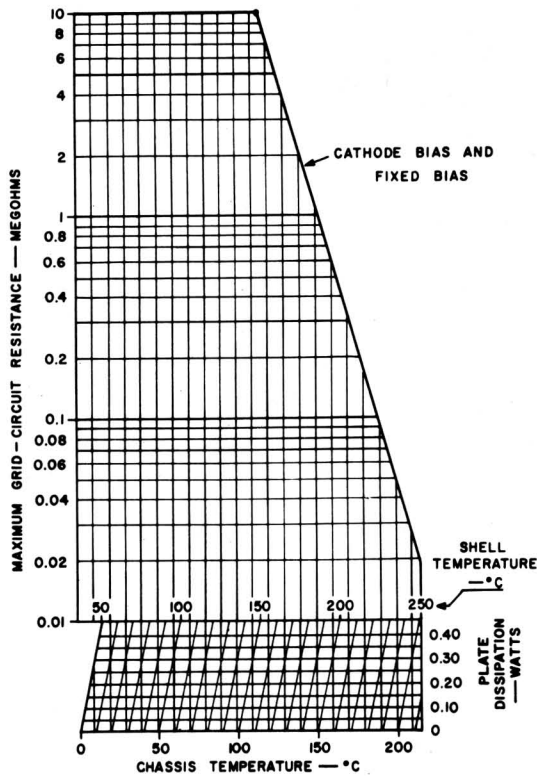

Fig. 10 - Nomograph for type 8056.

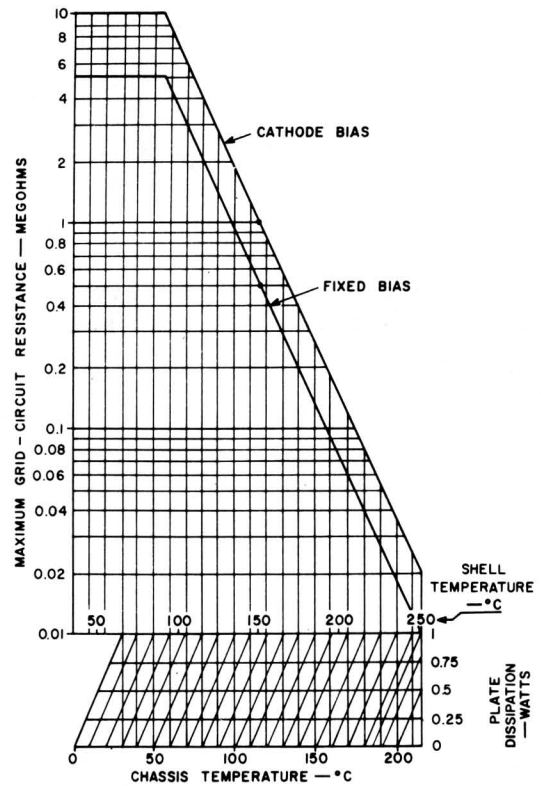

Fig. 11 - Nomograph for type 8058.